

# STEEP CONVEYOR – TYPE: PRO-SEN

**Reaching great heights with the SCHUMA steep conveyor type: PRO-SEN.**

With the SCHUMA steep conveyor, large differences in height can be overcome in a small space. The feed hopper of the conveyor is adapted especially to your requirements. Thanks to the special SEN steep conveyor base, the angle of the conveyor can be freely adjusted. The discharge chute can be used to supply the conveyed material exactly to the subsequent periphery.

**Benefits:**

- infinitely variable height adjustment
- conveyors with any width and length
- motor next to the conveyor belt (type: PRO-SEN) can be chosen
- motor under the conveyor belt (type: PRO-SEU) can be chosen
- different conveyor belt types possible
- clean room version possible
- feed hopper according to requirements
- conveying angle infinitely adjustable

AS = Axis spacing  
 W = Width of belt  
 H = Loading and discharge height  
 WH = Width of hopper  
 h = Loading height

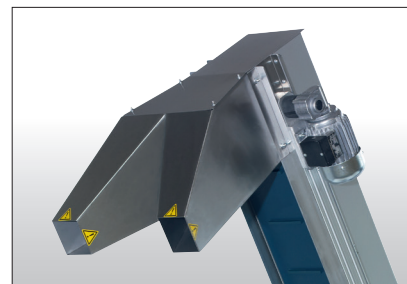
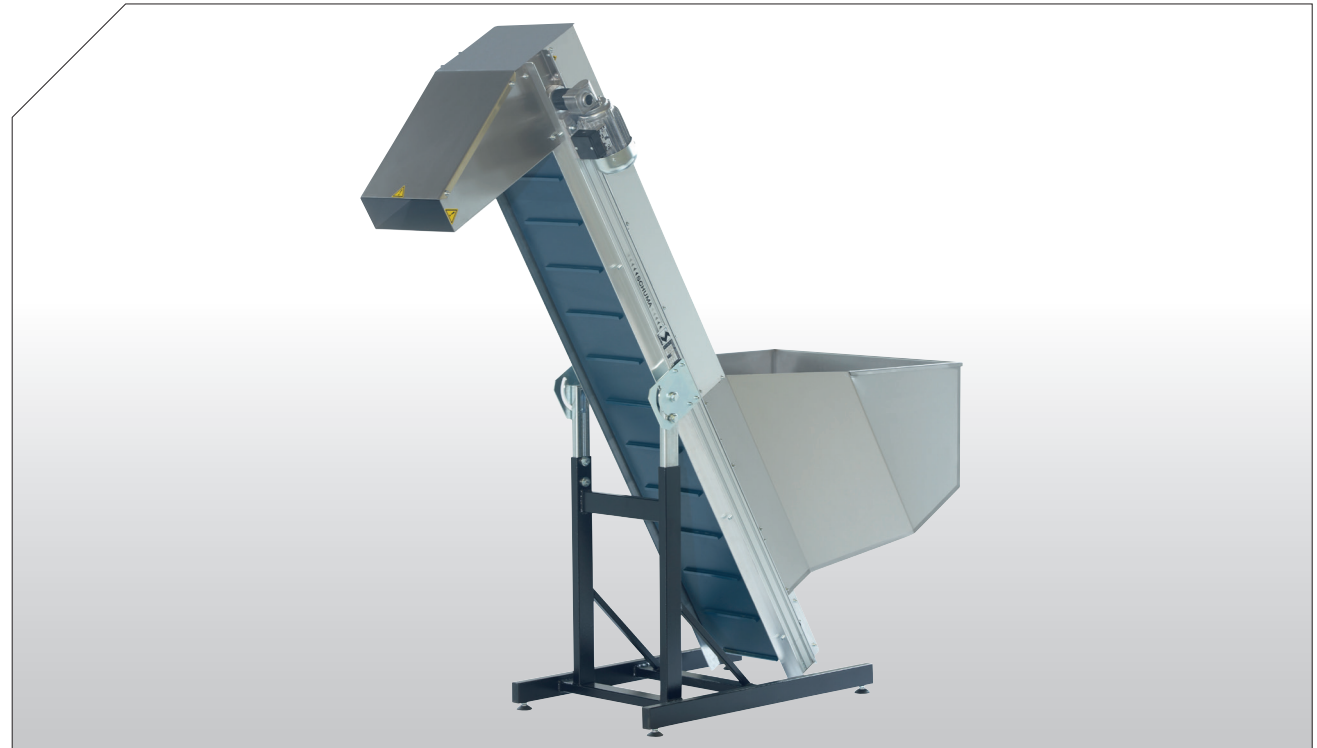
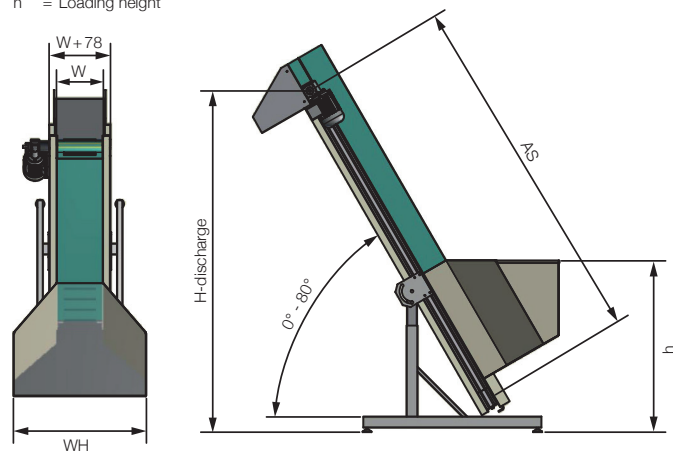

Double ejection chute to distribute the conveyed material through sorting gates.

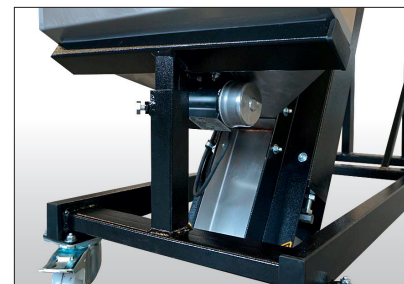

Vibrator on hopper underside to prevent clogging of the parts in the hopper.



Bunker conveyor.