

# CONVEYOR – TYPE: PRO-ZN

## The perfect helper for small differences in height.

Whether as a machine delivery conveyor or transfer conveyor, the PRO-ZN is very well suited for small space conditions thanks to its compactness.

### Benefits:

- infinitely variable height adjustment
- conveyors with any width and length
- motor next to the conveyor belt (type: PRO-EN ZN) can be chosen
- motor under the conveyor belt (type: PRO-EU ZU) can be chosen
- different conveyor belt types possible
- clean room version possible
- feed hopper

When used for heavy loads, we manufacture your conveyor with a steel frame.

### Regardless of the field of application, we can find the perfect solution for your needs.

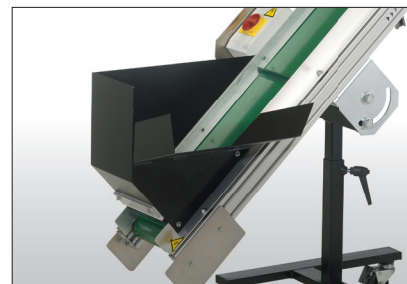
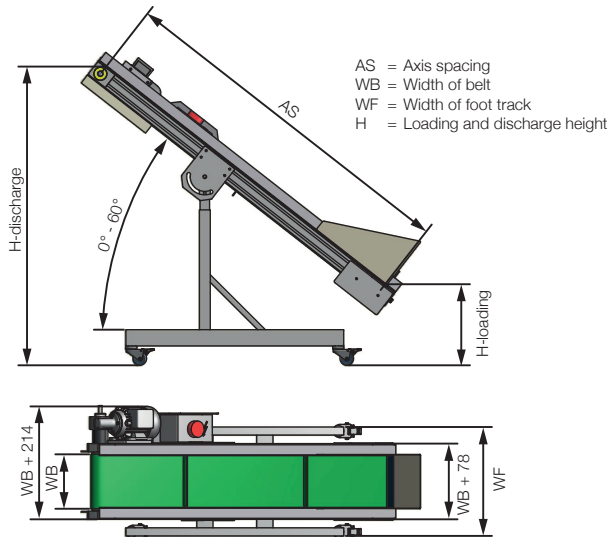

Feed hopper for supplying the conveyed material.

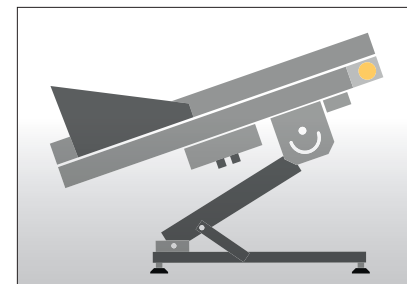

Using a manual crankshaft, the height of the scissor foot can be adjusted.



Discharge chute for supplying the conveyed material precisely.