

CONVEYOR – TYPE: PRO-EN/EU

The classic. The straight profile-conveyor.

The SCHUMA conveyor type PRO-EN/EU is the optimal solution for a linear conveyor section that is adapted exactly to your needs.

Benefits:

- infinitely variable height adjustment
- conveyors with any width and length
- motor next to the conveyor belt (type: PRO-EN) can be chosen
- motor under the conveyor belt (type: PRO-EU) can be chosen
- different conveyor belt types possible
- clean room version possible

We make your conveyor with a steel frame if it will be used for heavy loads.

Regardless of the field of application, we will find the perfect solution for your needs.

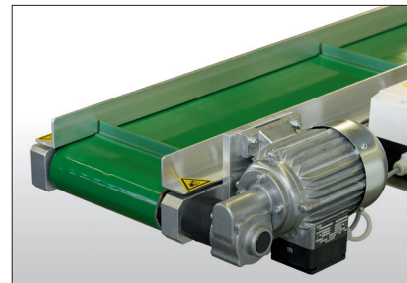
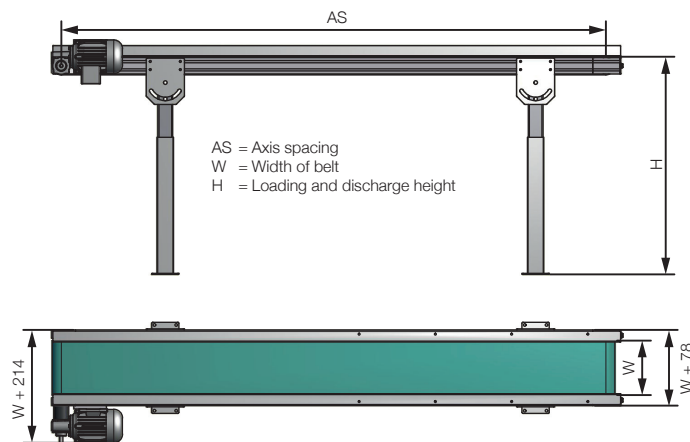

Motor installed next to the conveyor belt type: PRO-EN.

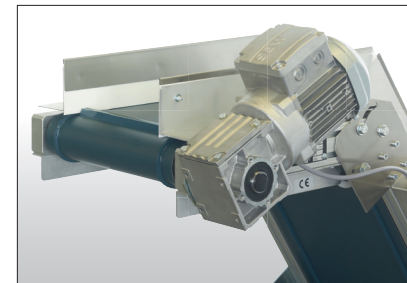

Spiroplan gear motor is used for heavy use cases.

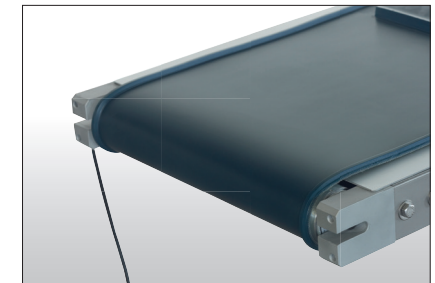

Drum motor type: PRO-E-TRO.