

MULTI-LEVEL SYSTEM

Up and down it goes with the SCHUMA multi-level system.

Supplying, filling and buffering of containers, cartons or small load carriers in a small space. The SCHUMA multi-level system provides this. The multi-level system automatically supplies and fills different containers on one level. And in the next step, containers are conveyed to the second level by a lift and then removed. The length of the loading and unloading conveyor can be freely selected depending on the container requirements. Unloading can be performed using a conveyor or an outfeed roller conveyor. The box changing process is controlled automatically by a control system integrated into the conveyor. The signal for changing a box is sent from the customer's machine. Using a pneumatic centring system, the container is precisely positioned in the filling position allowing for precise filling by the customer's handling system.

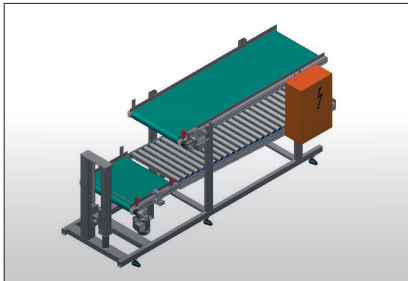
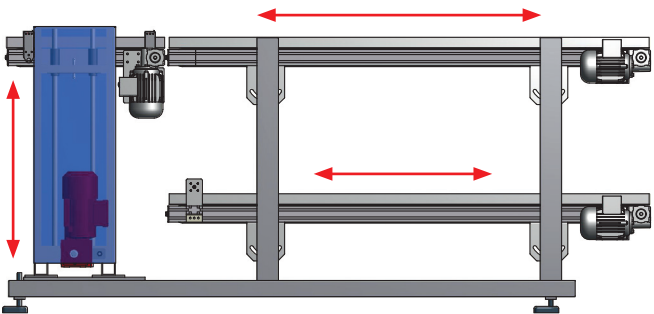
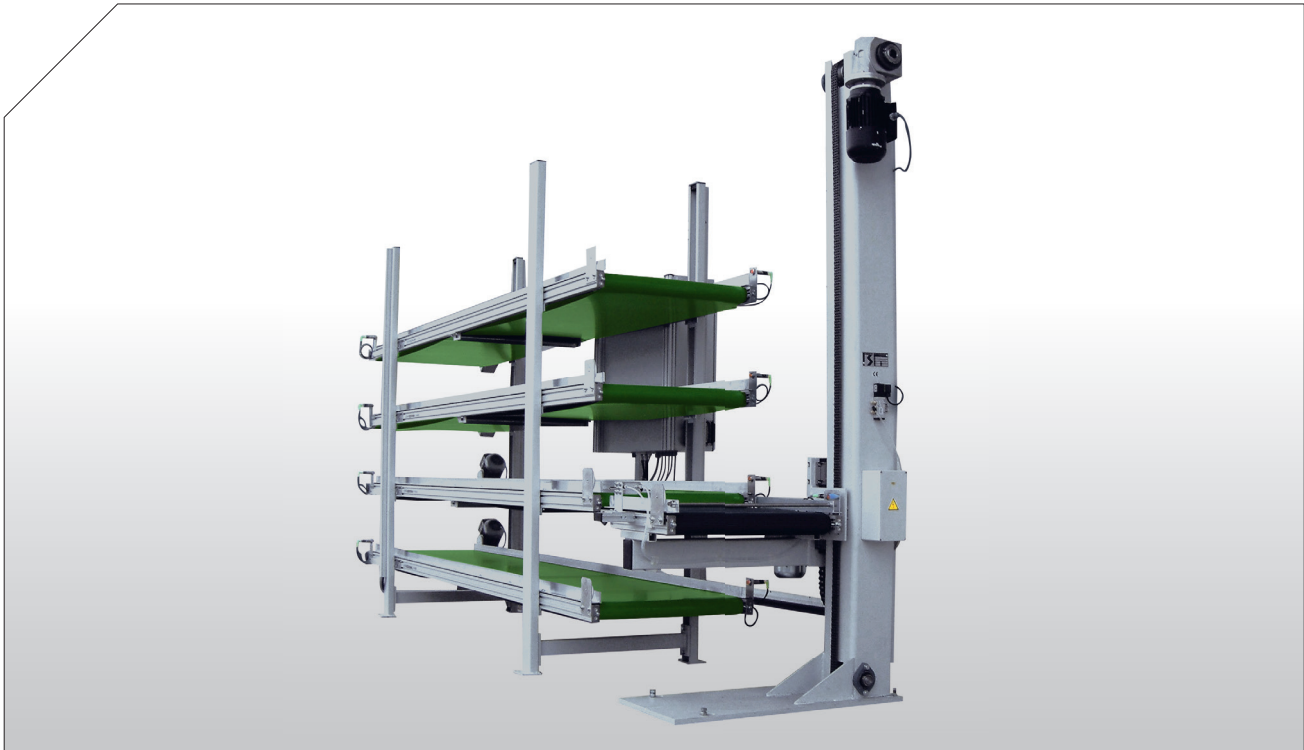

Multi level system with pneumatic lift and buffering roller conveyor.

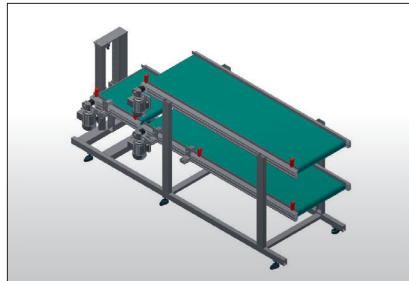

Multi level system with pneumatic lift and buffering conveyor.

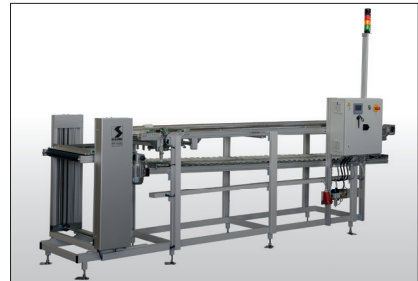

Multi level system with electric centering station.