

TIMING BELT CONVEYOR

Bare your teeth for more freedom.

In application cases that do not allow an enclosed protector, we use timing belt conveyors. It is easy to transport different conveyed materials by infinitely adjusting the width of the belt on the diverting and drive shaft.

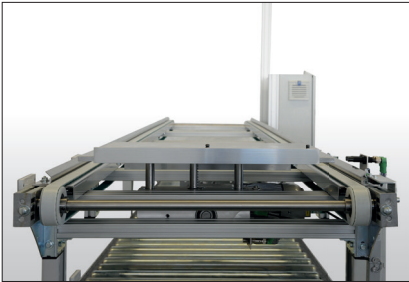
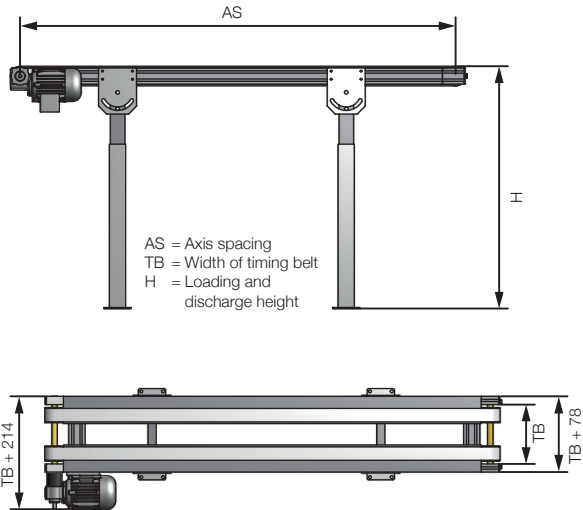

Timing belt conveyor with an electrical or pneumatic lifting station.



Chain conveyors.

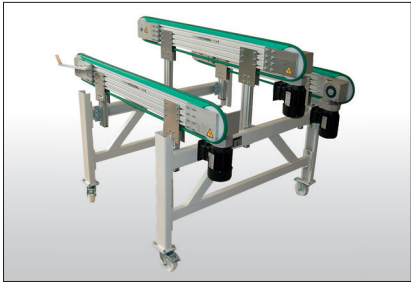

Round belt conveyor.